



C2M.v2.7.CCB~~v2.6~~

3.4.2.2 CC&B Manage Customer Risk

Creation Date: April 20, 2009

Last Updated: ~~February 11, 2020~~~~October 25, 2019~~~~February 7, 2019~~~~August 24, 2018~~

ORACLE®

Copyright © 2019, Oracle. All rights reserved.

This document is provided for information purposes only and the contents hereof are subject to change without notice.

This document is not warranted to be error-free, nor subject to any other warranties or conditions, whether expressed orally or implied in law, including implied warranties and conditions of merchantability or fitness for a particular purpose. We specifically disclaim any liability with respect to this document and no contractual obligations are formed either directly or indirectly by this document. This document may not be reproduced or transmitted in any form or by any means, electronic or mechanical, for any purpose, without our prior written permission. Oracle, JD Edwards, PeopleSoft, and Siebel are registered trademarks of Oracle Corporation and/or its affiliates. Other names may be trademarks of their respective owners.

Contents

BRIEF DESCRIPTION	4
BUSINESS PROCESS MODEL	5
DETAIL BUSINESS PROCESS MODEL DESCRIPTION.....	<u>10</u>
TEST DOCUMENTATION RELATED TO THE CURRENT PROCESS	<u>12</u>
DOCUMENT CONTROL	<u>13</u>
ATTACHMENTS	<u>14</u>
<i>Account Page</i>	<u>14</u>

Brief Description

Business Process: 3.4.2.2 C2M.CCB Manage Customer Risk
Process Type: Sub-Process
Parent Process: 3.4.2 C2M.CCB Develop Insight and Understanding
Sibling Processes:

This process describes how the CSR or Authorized User determines if a Customer's, internal or external, credit or cash-only score is at risk and the effects that cause credit risk.

Business Process Model

3.4.2.2 C2M.v2.7.CCB_v2.6:Manage Customer Risk

3.4.2.2 C2M.CCB.v2.6 *Manage Customer Risk*

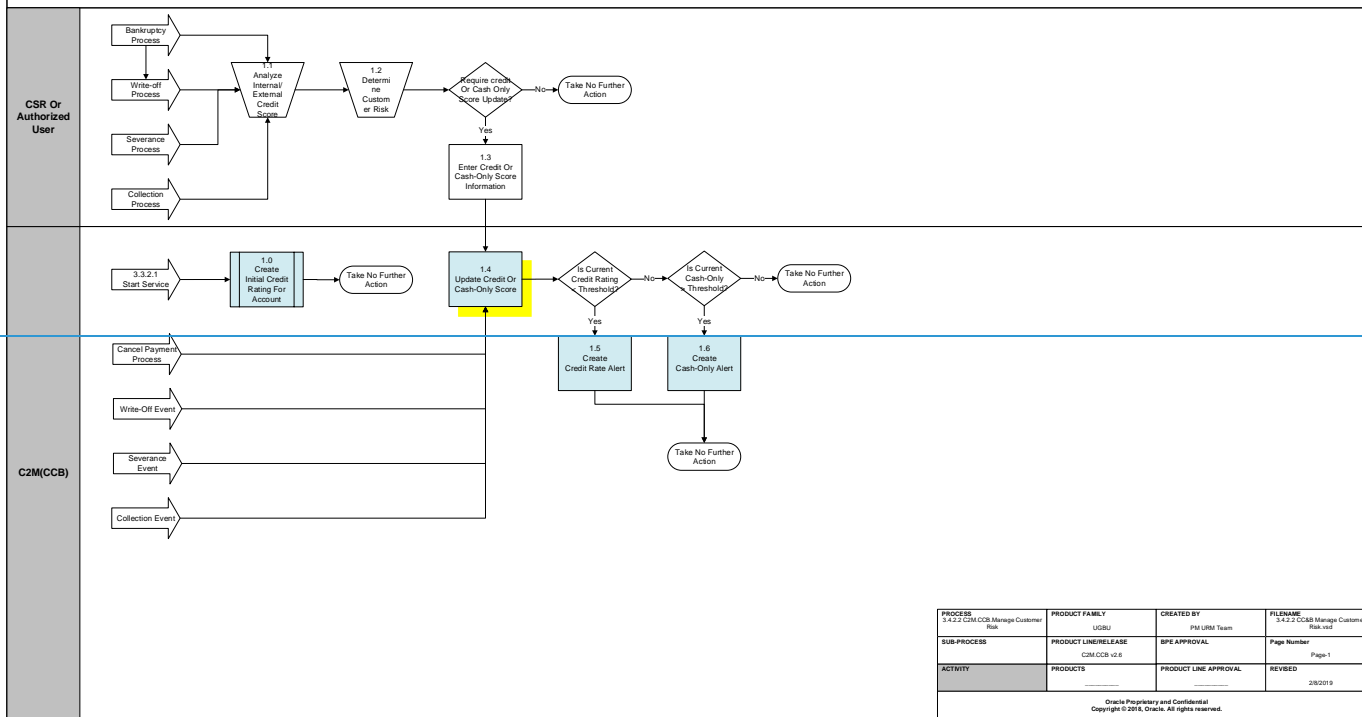

Field Code Changed

PROCESS	3.4.2.2 C2M.CCB.Manage Customer Risk	PRODUCT FAMILY	UGRU	CREATED BY	PM URM Team	FILENAME	3.4.2.2 CCB.Manage Customer Risk.pdf
SUB-PROCESS		PRODUCT LINE/RELEASE	CCM.CCB.v2.6	SPE APPROVAL		Page Number	Page 1
ACTIVITY		PRODUCTS		PRODUCT LINE APPROVAL		REVISED	2/8/2019

Oracle Proprietary and Confidential
Copyright © 2019, Oracle. All rights reserved.

3.4.2.2 C2M.v2.7.CCB_v2.6.Manage Customer Risk

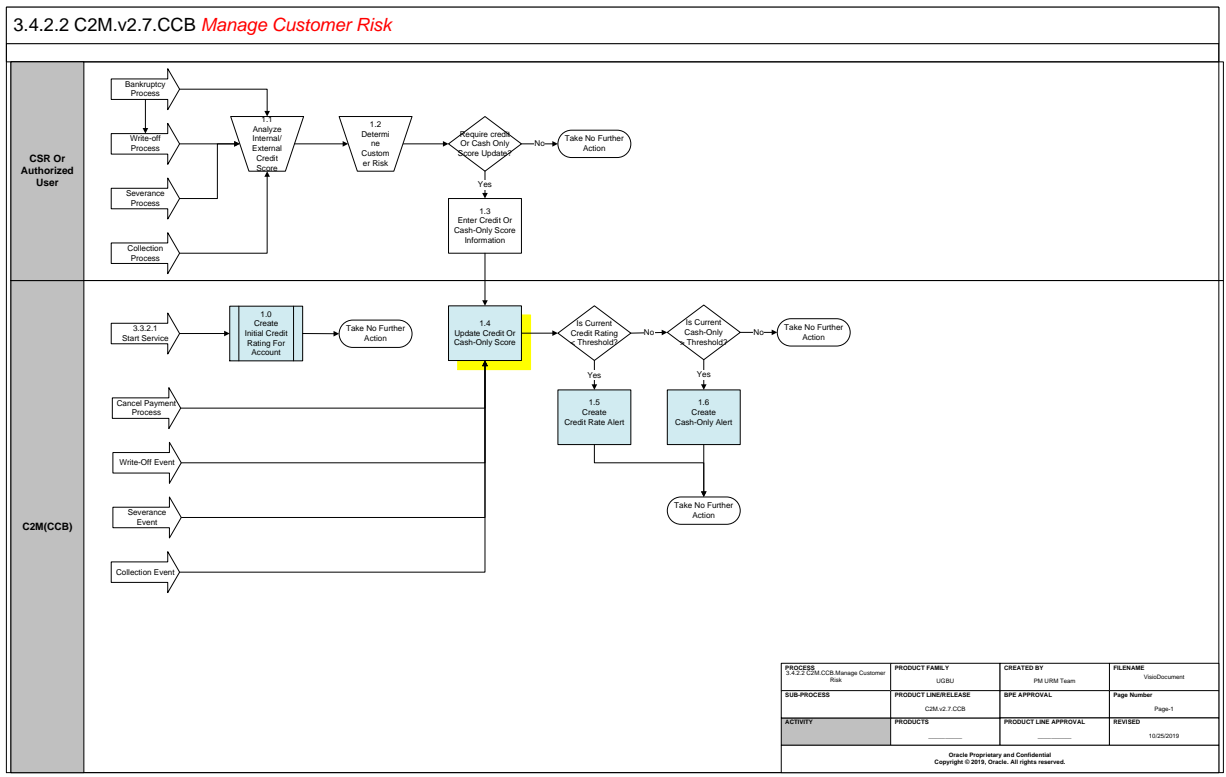

Field Code Changed

3.4.2.2 C2M.v2.7.CCB_v2.6.Manage Customer Risk

3.4.2.2 C2M.v2.7.CCB_v2.6:Manage Customer Risk

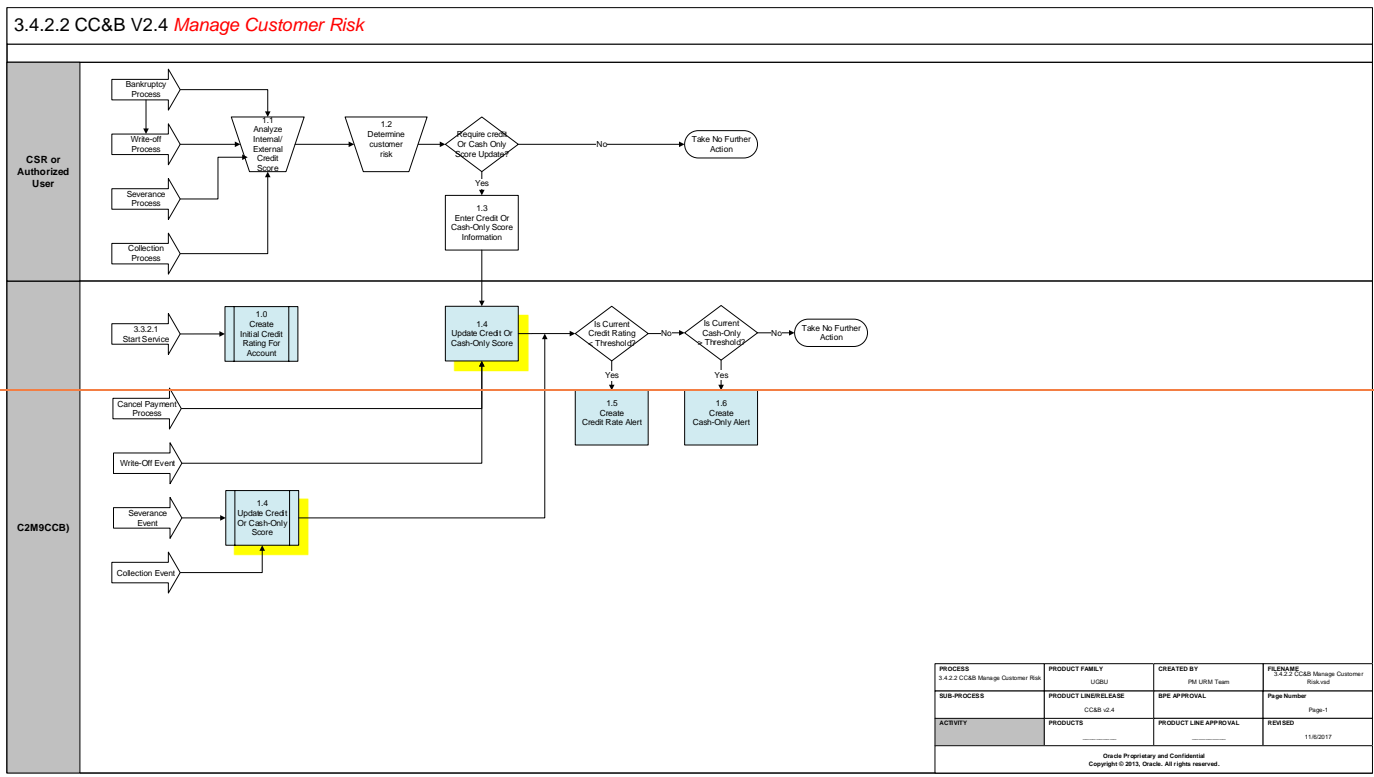

3.4.2.2 C2M.v2.7.CCB_v2.6:Manage Customer Risk

3.4.2.2 C2M.v2.7.CCB_v2.6:Manage Customer Risk

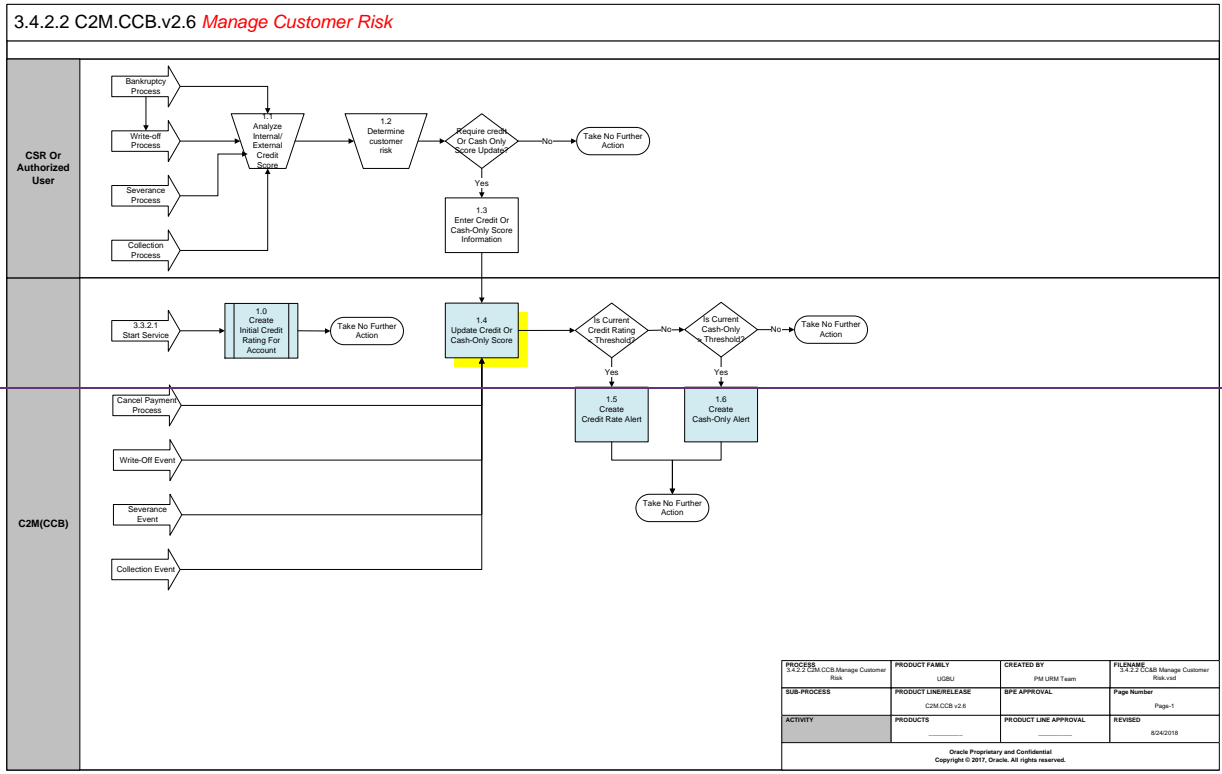

Field Code Changed

3.4.2.2 C2M.v2.7.CCB_v2.6:Manage Customer Risk

Detail Business Process Model Description

1.0 Create Initial Credit rating for Account

Actor/Role: C2M(CC&B)

Description:

The Start service [process](#) automatically creates a credit rating on [an Account](#).

Configuration required Y

Entities to Configure:

Install Option Credit Score (C&C) information.

Process Plug-in enabled Y

Available Algorithm(s):

C1-CBYI-DFLT (CBYI-DFLT)
This algorithm formats the information for a credit rating history transaction record based on the event that created it.

1.1 Analyze Internal/External Credit Score

Actor/Role: CSR [or Authorized User](#)

Description:

CSR manually reviews customer's ~~account~~ [Account](#) credit or cash-only score.

1.2 Determine customer risk

Actor/Role: [CSR](#) [or Authorized User](#) ~~CSR~~

Description:

The CSR decides if [a](#) customer's credit or cash only score is at risk.

1.3 Enter credit or cash-only score information

Actor/Role: [CSR](#) [or Authorized User](#) ~~CSR~~

Description:

If [an](#) update is required, enter [the](#) customer's credit or cash-only score on [the Account Page](#) ~~credit~~ [Credit](#) and ~~collections~~ [Collections](#) tab.

1.4 Update credit or cash-only score

Actor/Role: C2M(CC&B)

Description:

The system updated [the e](#)Customer credit or cash-only score. An account's credit or cash-only score is defined on the installation algorithm to automatically sum the ~~effect~~ [on the credit](#) ~~Rating~~ [Credit rating](#) or ~~cash~~ [Cash](#)-only ~~score~~ [Score](#). The Customer's internal credit ratings and cash-only scores are automatically generated through a system of event type algorithms such as ~~collection~~ [Collection](#), ~~severance~~ [Severance](#) and ~~write~~ [Write](#).

~~off-Off events~~Events. A ~~payment~~Payment ~~tender~~Tender cancel reason for non-sufficient funds or a broken ~~pay~~Pay ~~plan~~Plan can be configured to create ~~the~~eCredit #Rating.

Process Plug-in enabled Y Available Algorithm(s):

COLL EVT GEN (COLL EVT GEN) (This is a sample generic collection event algorithm.)
SEV EVT GEN (SEV EVT GEN) (Sample generic severance event algorithm). See C1-CE-CR-RT cut event activation algorithm creates a credit rating history record for the account associated with the cut process' overdue process.
WO EVT GENER (WO EVT GENER) (Generic Write Off Event Algorithm)
C2M-BROKEPP (BROKEN PP) broken pay plan algorithm inserts a credit rating history record for an account when a pay plan is broken

Configuration required Y Entities to Configure:

Cancel Reason
Broken Pay Plan

1.5 Create Credit Rate Alert

Actor/Role: C2M(CC&B)

Description:

If credit rating is less than ~~the~~threshold defined on the installation algorithm, an alert is automatically created.

Process Plug-in enabled Y Available Algorithm(s):

C1_CRRT-DF (C1-CRRT-ACCT) (Credit Rating Alert)

1.6 Create Cash-Only Alert

Actor/Role: C2M(CC&B)

Description:

If cash-only score is greater than threshold defined on the installation algorithm, an alert is automatically created.

Process Plug-in enabled Y Available Algorithm(s):

C1_CASH-DF (C1-CASH-ACCT) (Cash Only Account)

Test Documentation related to the Current Process

ID	Document Name	Test Type

Document Control

Change Record

Date	Author	Version	Change Reference
4/20/09	Stephanie Rogers	Draft 1a	No Previous Document
10/21/10	Geir Hedman		Update Title and Content page
12/06/10	Ze'ev Lavee		Technical Alg Updates
2/8/10	Geir Hedman		Updated Document and Visio
11/13/13	Dean Davis		Updated Document and Visio
11/30/2013	Galina Polonsky		Reviewed, Approved
09/07/2017	Ekta Dua		Updated Document and Visio to v2.6
09/21/2017	James Foreman		Updated algorithms
10/30/2017	Galina Polonsky		Reviewed, Approved
08/24/2018	Jerry Chick		Replaced Visio flow diagram with updated version. Several grammatical and syntax corrections.
09/21/2018	Galina Polonsky		Reviewed, Approved
06/03/2019	Satya Kalavala		Updated format for v2.7

Formatted: Font: 5 pt, Font color: White, Do not check spelling or grammar

Formatted Table

Formatted Table

Formatted Table

Attachments

Account Page



Internal Credit
Rating_Cash-Only Sc